

QUILT GIRL Portfolio

Designed by Whistler Studios
Featuring the Quilt Girl Collection by Whistler Studios
Size: 27" x 21"



Check www.windhamfabrics.com Free Project section to see if there are any pattern updates before you start your quilt project

WINDHAM FABRICS

812 Jersey Ave ~ Jersey City, NJ 07310 ~ 201.659.0444 ~ FAX: 201.659.9719
www.windhamfabrics.com email: retail@windhamfabrics.com

QUILT GIRL Portfolio



Designed by Whistler Studios
Featuring the Quilt Girl Collection by Whistler Studios
Size: 27" x 21"

*When you go to your guild meeting or friend's house, wouldn't it be nice to have a case that could hold your cutting mat, rotary cutter, pins, tape measure and other supplies?
This handy portfolio is the perfect carry all. It has pockets inside that hold lots of supplies and your 18 x 24" cutting mat fits perfectly.*



37315-X



37316-X

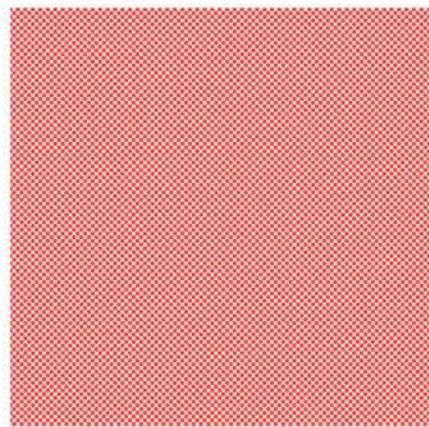

37318-2

Fabric Requirements:

- 1 ¼ yards 37315-X Multi Quilt Girl pattern for Outside
- 1 ¾ yards 37316-X Multi Comic Strip for Lining
- 1 2/3 yards 37318-2 Red Mini Dot for Handles and Binding
- 1 ½ yards Batting
- 1 2/3 yards fusible interlining for handles
- 1 ½ yards of ½" Black Velcro

Cutting:

- 37315-X Multi Quilt Girl
 - Cut (1) 27" x 42" rectangle
- 37315-X Multi Comic Strip
 - Cut (1) 28" x 43" rectangle
 - Cut (1) 27" x 20 ½" rectangle for inside pocket
- 37318-2 Red Mini Dot
 - Cut (2) 3 ½" x 60" for handles (cut lengthwise)
 - Cut (4) 2 ¼" x Width of Fabric strips for binding **after** cutting the handles
- Batting
 - Cut (1) 28" x 43" rectangle
- Fusible Interlining
 - Cut (2) 3 ½" x 60" for handles



Assembly:

Portfolio case

1. Take batting and sandwich it between the Quilt Girl fabric (outside) and the lining. Quilt using your favorite design. Trim the batting and lining to fit the outside fabric piece.
2. Fold in half with lining side together and mark the fold line with fabric marker, grease chalk or pins. Stitch on the line you marked. This will create the bottom edge of the portfolio case.
3. With right sides together, take the comic strip pocket fabric and fold in half the long way and machine stitch the long edge closed. Turn and press the seam flat. The seam will be the bottom edge of the pocket. Diagram 1 & 2



Diagram 1



Diagram 2

4. With lining side of portfolio case up, take the pocket and place it just above the bottom stitch line. Stitch the pocket with an edge stitch at the bottom and up the sides. Diagram 3
5. Take the (4) 2 ¼" x WOF strips and sew them together to form the binding fabric. Bind off the portfolio case on all sides. Set aside.

Handles

1. Take (1) 3 ½" x 60" strip and apply the fusible interlining following the manufacturer's recommended instructions. With right sides together, fold in half and stitch one end and the long side. Turn and press flat. Edge stitch both sides of the handle. Repeat for the other handle piece.
2. With outside facing up, measure the center point of the portfolio at the top edge. Measure 3" in both directions and place a pin at these points. Once you establish these points, measure in from the side to that point. It should be about 10 ½". (sewing styles might alter measurement slightly – it is important that the handles remain 3" from the center on each side) Diagram 4

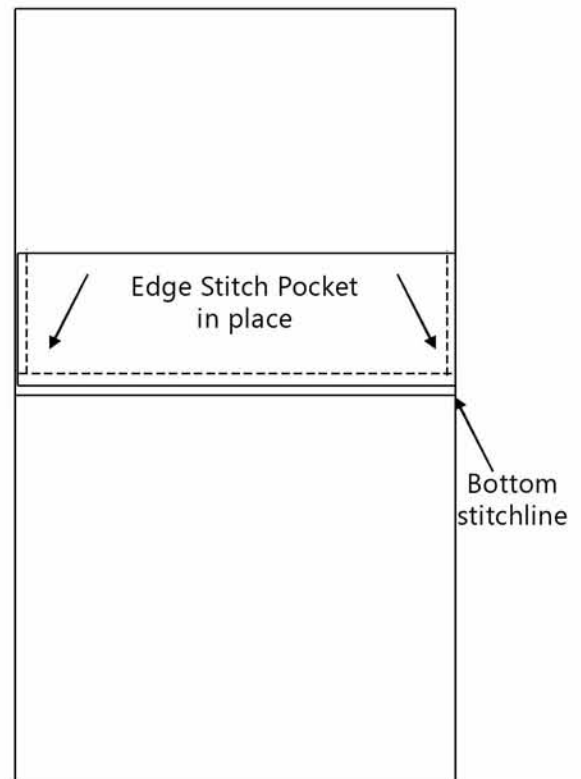

Diagram 3



3. Then measure down the portfolio to the bottom placing pins or markers. This is where you will put the inside edge of the handles starting at the bottom. Extend the handle $\frac{1}{4}$ " beyond the bottom stitch line as the handles will overlap at this point when other side is completed. Edge stitch the handles in place starting at the bottom. Stitch across the top at the binding edge to secure for wear and tear. Repeat for the other side. Diagram 4
4. Repeat for the other side of the portfolio insuring the handles at the top and the overlap at the bottom match the other side.
5. Take the bottom edge of one side of the handle and overlap over the other side and edge stitch closed after turning under raw edge. Diagram 5

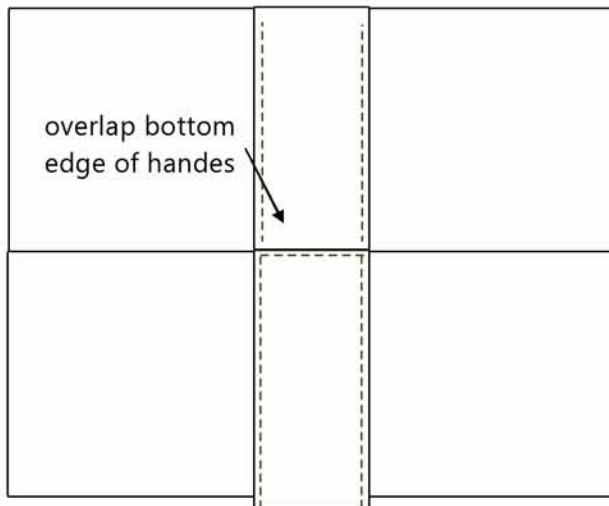

Diagram 5 (detail of bottom handle join)

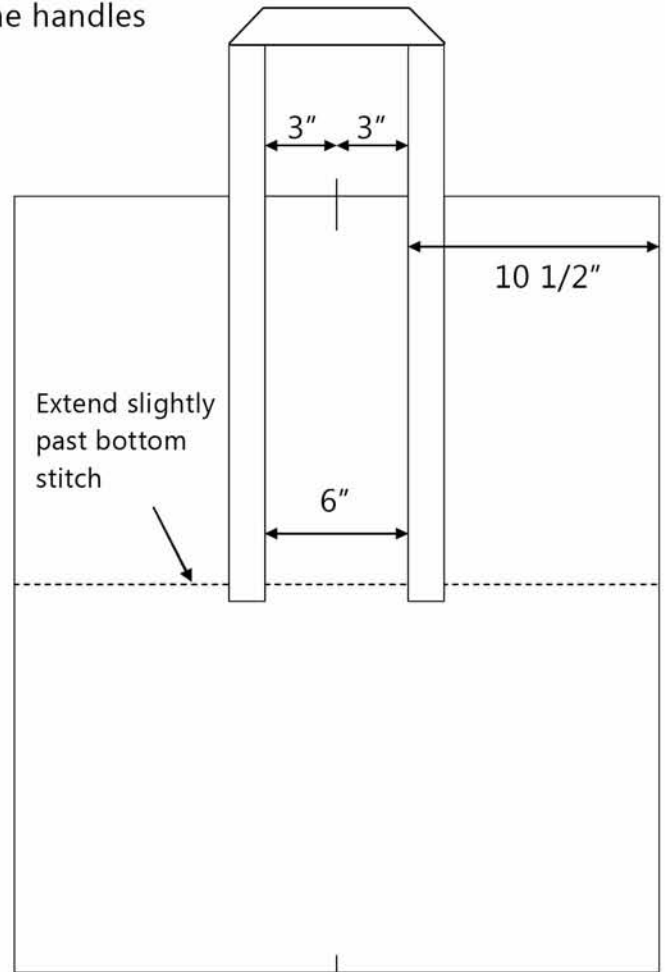

Diagram 4

6. Once the handles are stitched, they automatically create 3 pockets inside the portfolio case for your various supplies. See Diagram 6 next page



7. Take the Velcro and cut a strip the width the portfolio minus the binding. Stitch the Velcro as instructed by the manufacturer at the top edge of the portfolio just below the binding.
Diagram 6
8. Cut (2) 5" pieces of the Velcro and place them on each side of the portfolio at the top of the pocket and inside edge of binding. Machine stitch in place as instructed by the manufacturer. This will keep the side closed so your cutting mat will not slide out.

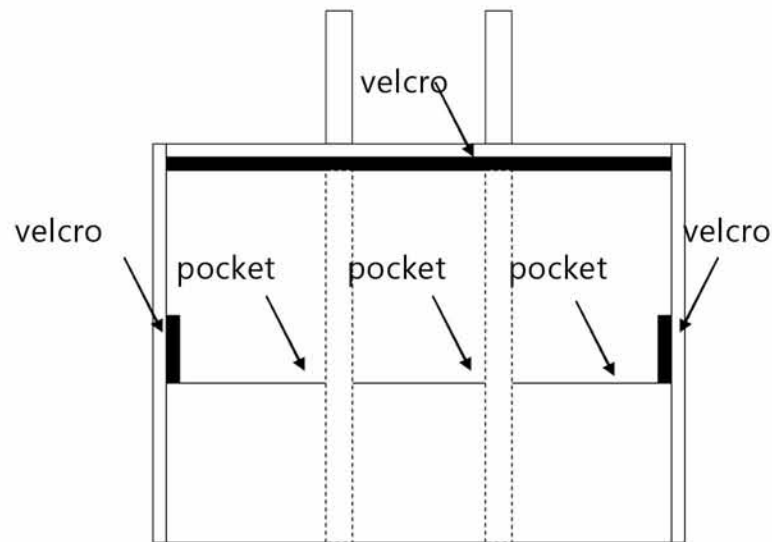

Diagram 6

Your portfolio is ready to load up with your supplies and go!!



Be sure to visit www.windhamfabrics.com to see the complete collection and to download other Free Projects