

Juliet Getaway Bag

Print Patterns used to make this bag



30896-2 Purple



30897-2 Purple



30901-3 Green



30899-2 Purple

Learn more about Paige Stanley Miller by visiting her website:
www.costalpreppy.com

Be sure to visit www.windhamfabrics.com to see the complete collection
and to download this and other Free Projects

WINDHAM FABRICS

812 Jersey Ave ~ Jersey City, NJ 07310 ~ 201.659.0444 ~ FAX: 201.659.9719 ~ info@windhamfabrics.com

Juliet Getaway Bag

Designed by Paige Stanley Miller
Instructions provided by Irene Berry
Featuring fabric from the Juliet Collection



WINDHAM FABRICS

Juliet Getaway Bag

Designed by Paige Stanley Miller

Instructions by Irene Berry

Featuring the Juliet Collection by Paige Stanley Miller

Bag size 18" x 14"

Fabric and Supplies:

5/8 yd. 30896-2 purple (large scale lavender floral)

1/2 yd. 30897-2 purple paisley stripe (wide stripe)*

1/2 yd. 30901-3 Lace/leaf (green and white print)

1/2 yd. 30899-2 purple paisley on cream ground

also needed:

2 yds. medium-weight iron-on interfacing

freezer paper or template plastic

Velcro or snap closure

**This yardage is for fussy cutting a wide vertical stripe. If substituting a fabric that can be cut crosswise, 1/4 yard is enough.*

Assembly:

Note: Use 1/4" seam allowances throughout this project unless otherwise noted.

1. From the Juliet/violet (large scale lavender floral) cut 1 bag panel 18 1/2" x 23 1/2" and 2 side gussets each 4 3/4" x 10". Cut a piece of interfacing the same size as each Juliet piece. Following the manufacturer's directions for the interfacing, press the interfacing to the wrong sides of the bag panel and side gussets.
2. With right sides together, pin the gussets to the bag panel. Tip: Pin both sides of the gusset to the bag panel first, and then pin the bottom of the gusset. Stitch in place, starting and stopping the stitching 1/2" away from the top edges. Press the seam allowances open. Turn the bag right side out.
3. From the Camille paisley stripe, cut 4 handles each 1 3/4" x 16". Refer to the bag photo to see which part of the stripe to cut. Cut 4 strips of interfacing the same size. Press an interfacing strip to the wrong side of each handle strip. Place two strips right sides together and stitch along both long edges. Turn right side out and press. Repeat.

4. Make a template for the scalloped flap. From the Lace /leaf (green and white) print, cut 4 bands each 3 1/2" x 12 1/2" and 4 pieces of interfacing the same size. Apply the interfacing to the wrong side of each band. On the wrong side of an interfaced band, mark the scallop 1/4" away from the long edge. With the marked band on top, sew 2 bands right sides together. Sew along both short edges of the band and on the marked line. With a small, sharp scissors, trim the excess fabric, leaving 1/4" seam allowance. Clip the inside points. Turn the flap right side out and press. Make 2.
5. Also from the Lace/leaf print, cut 4 bands each 3" x 12 1/2". Cut 4 pieces of interfacing the same size and apply to the wrong side of each band. Right sides together, layer a band and a scalloped flap, and another band, aligning the long raw edges. Pin around three sides. Insert the ends of one handle between the ruffle and the top band, handle ends aligned with the raw edges. Sew around three sides, starting and stopping the stitching 1/4" away from the raw edges. On the short sides, use a very scant seam (1/8") to avoid catching the sides of the scalloped flap in the seams. Turn right side out and press. Make 2.
6. By hand, sew a running stitch along both top edges of the main bag panel. Pull the thread to gather the edge of the bag so that it fits the 12 1/2" edge of the band. Right sides together and aligning raw edges, stitch the outer band (the one closest to the scalloped flap) to the gathered edge of the bag. Repeat for the other side of the bag.
7. From the Camille paisley (cream print), cut 1 bag lining panel 16" x 23" and 2 gussets each 4 3/4" x 10". In the same manner as for the bag, pin and stitch the gussets into the bag lining, starting and stopping the stitching 1/2" away from the top edges. Press the seam allowances open. Keep the lining inside out.
8. Slip the bag inside the lining, right sides together. Match the seams and pin across the tops of the gussets. Stitch across the tops of the gussets. Turn the lining right side out and push it into the bag. In the same manner as for the outside of the bag, gather one raw edge of the lining so it fits in the bag. Turn under 1/4" along the raw edge of the green band and pin it to the lining. Stitch the band to the lining by hand. Repeat for the remaining side.
9. By hand, sew a Velcro closure or a snap close to the top edges of the bag.



ENJOY!





Juliet Getaway Bag



Template for Scalloped band at top of bag

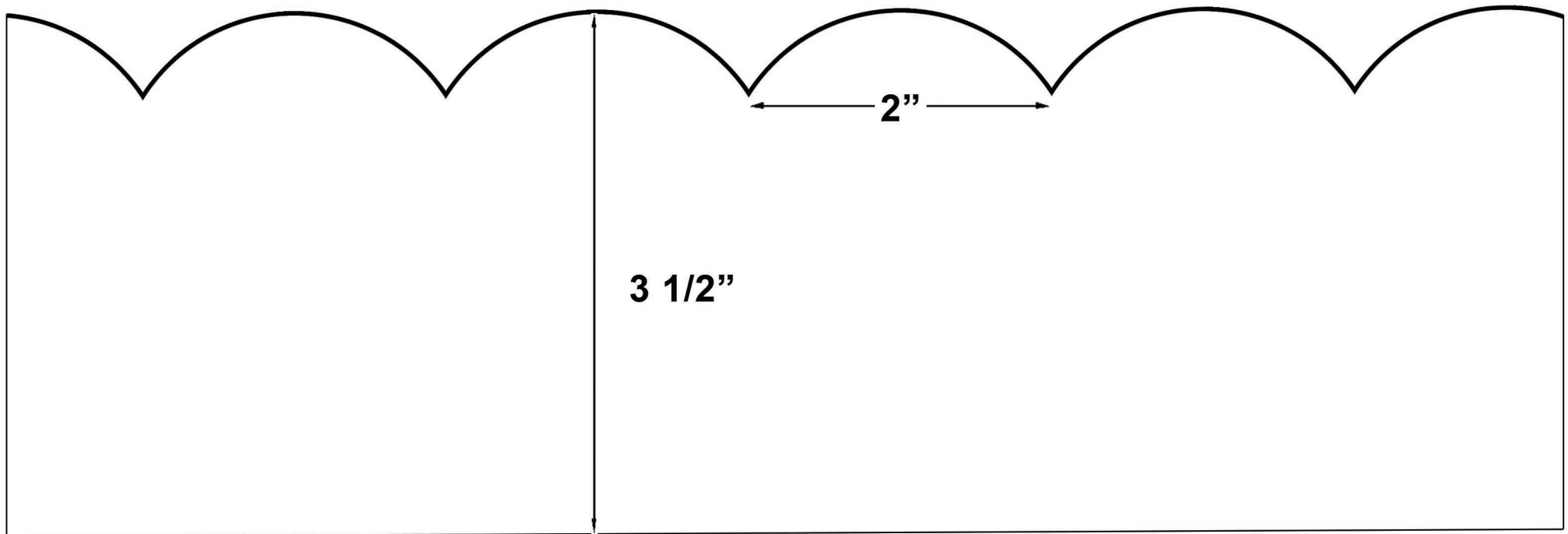

Scallop is correct to size (each scallop measures 2" point to point)

Height of scallop piece is 3 1/2"

Length should be increased to 12 1/2"

(as per assembly item #4)